

Datasheet

Version 1.1
29/06/26

hargrave technologies.com



Contents

01 Safety	2
02 At a Glance	3
03 Specifications	4
04 Quick Start	7
05 Integration	8
06 Cooling & Performance	12
07 Protection Systems	15
08 Ordering Options	16
09 Pinouts	17
10 Powered by GateKEEPER	18
11 Revisions	19
12 Disclaimer	19

01 Safety

We recommend reviewing this datasheet before getting started.

microFLUX 2MPi has been designed and tested for reliability, but incorrect installation or operation can cause damage or safety hazards.



Power supplies channel substantial power. Fault currents can exceed 100 A and while extremely rare, major failures can result in fire. Design your vehicle accordingly. Power supplies should be fused from batteries and isolated from flammable components.



Always ensure you are connecting the power supply with the correct polarity.



Never exceed the rated voltage of the power supply, doing so can result in premature failure.



microFLUX 2MPi is provided as an exposed bare board for integration into other devices. Direct exposure to water, debris or physical impact can result in unit failure.



Do not attempt to disassemble or modify the microFLUX 2MPi. Doing so will void your warranty and more importantly, can cause damage that results in a failure.



While there are multiple fail-safes in place, it should be assumed that a powered unit can output to a connected load at any time. Take appropriate precautions.



Depending on usage conditions, components on the microFLUX 2MPi board may reach high temperatures during normal operation. Ensure an adequate thermal solution for your application and avoid contact with the unit when hot.



The large area of exposed copper on the top of the microFLUX 2MPi is live. Avoid contact with the unit when powered to avoid shocks, burns and short circuit. We recommend covering this area with an electrically non-conductive, thermally conductive material.



microFLUX 2MPi is a bareboard, dual-channel smart power supply built for seamless integration into higher-current payloads.

Optimized for tight packaging constraints, it allows integration directly into the airframe, reducing cable runs and delivering configurable power closer to the critical systems that need it.



02 At a Glance



15 – 60 V

INPUT VOLTAGE

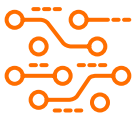

DroneCAN

TELEMETRY & CONTROL



>98%

PEAK EFFICIENCY



3.3 – 28 V

ADJUSTABLE OUTPUT
VOLTAGE

FULL LIST OF SELECTABLE OUTPUTS ON PAGE 6



2 x 20 A

OUTPUT CHANNELS



55 g

BASE WEIGHT

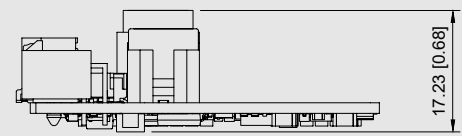
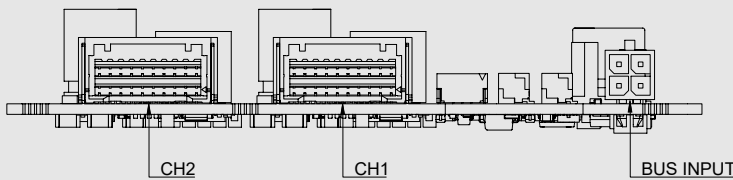
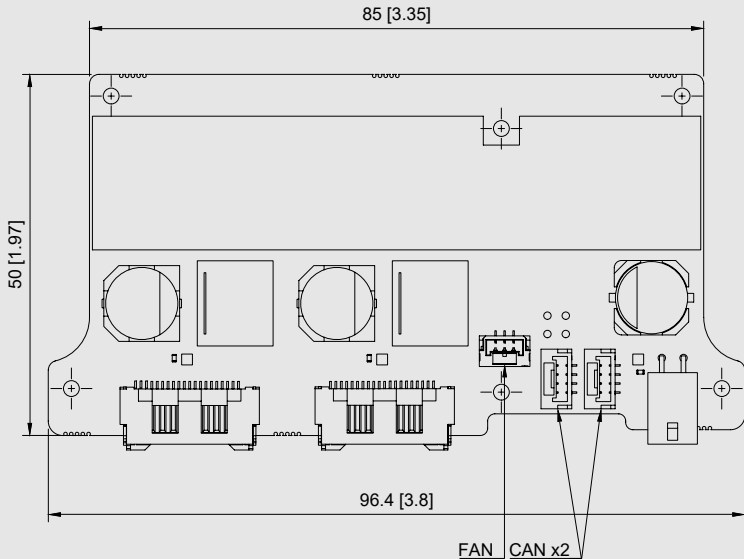

All dimensions in mm [inches].

Looking for the CAD?

Click below to find the new microFLUX 2MPi CAD:

hrgve.tech/uF-2MPi_CAD



03 Specifications

General

PARAMETER (UNIT)	VALUE	NOTES
Recommended Supply Voltage	(V) 15 – 60 [4S – 14S]	The recommended operating range for the unit.
Absolute Supply Voltage Range	(V) 13 – 63	Breaching absolute limits will result in unexpected shutdowns or unit failures.
Maximum Input Current	(A) 22	Depends on crimp selection and wire gauge. See 05 Integration for details.
Input Overvoltage Protection	Configurable	Configurable warning/disable for overvoltage event.
Input Undervoltage Protection	Configurable	Configurable warning/disable for undervoltage event.
Input Overcurrent Protection	Configurable	Configurable warning/disable for overcurrent event.
Input Voltage Measurement Accuracy	(%) ± 2	Input voltage measurement accuracy across the full-scale range.
Input Current Measurement Accuracy	(%) ± 2	Input current measurement accuracy across the full-scale range.
CAN Bus Support	Isolated DroneCAN	CAN is isolated to prevent ground loops.
Recommended CAN Supply Voltage	(V) 5 – 12	External power required between CAN V+ and CAN GND pins for CAN functionality.
Absolute Maximum CAN Supply Voltage	(V) -0.3 – 18	Relative to CAN GND pin.



PARAMETER (UNIT)	VALUE	NOTES
CAN Isolation Voltage	(V) ± 63	Isolation for functionality only, not intended for safety.
CAN Signal Common Mode Range	(V) 12	CAN H / CAN L to CAN GND.
Maximum CAN Signal Differential Voltage	(V) 5	CAN H to CAN L, when termination is enabled.
CAN Bus Termination	✓	Software-controlled termination resistor.
Precharge	✓	Bulk capacitance has inbuilt precharge to reduce inrush current.
Integrated Fan Output	✓	–
Fan Output Voltage	(V) 12	Built in short circuit protection.
Fan Maximum Current	(mA) 200	Built in short circuit protection.
Per Channel Power Enable/Disable	✓	Via DroneCAN.
Firmware Updates	✓	Via CAN interface.
Configurator Tool	✓	CAN accessible configuration.
Data Logging	✓	Configurable rate, automatic circular logging.
Self-Correcting Memory	✓	Use of onboard backups and ECC memory.
Anti-Spark	✓	Built in anti-spark protection.
RGB Indication LED	✓	One indicator per output plus an overall system indicator.
NDAA Compliance	Standard	–
Country of Origin	Australia	–
RoHS/REACH Compliance	✓	–

Channel Specifications

PARAMETER (UNIT)	VALUE	NOTES
Rated Continuous Current	(A) 20	Depends on thermal solution, input voltage, output voltage, total input current and ambient temperature. See 06 Cooling & Performance for more details.
Rated Peak Current	(A) 24	Depends on thermal solution, input voltage, output voltage, total input current and ambient temperature. See 06 Cooling & Performance for more details.
Output Voltage	(V) Refer to page 6 for full list.	Digitally configurable.
Absolute Maximum Voltage	(V) -0.3 - 35	Breaching absolute limits will result in unexpected shutdowns or unit failures. It is not recommended to back-feed output channels at any time.
Maximum Output Capacitance	(mF) $V_{out} \leq 12 V = 6.0mF$ $V_{out} > 12 V = 2.0mF$	Depends on output voltage. Excess capacitance can cause start-up issues. See 06 Cooling & Performance for more details.
Drop Out Voltage	(V) 2	Minimum voltage between input and output to guarantee performance specification.
Voltage Measurement Accuracy	(%) ± 0.3	Voltage measurement accuracy across the full-scale range.
Current Measurement Accuracy	(%) ± 1	Current measurement accuracy across the full-scale range.
Nominal Output Rise Time	(ms) 2.75	–
Auto Power On	Configurable	Configurable automatic power on when input applied.
Output Overvoltage Protection	Configurable	Configurable warning/disable system for overvoltage event.
Output Undervoltage Protection	Configurable	Configurable warning/disable system for undervoltage event.
Output Overcurrent Protection	Configurable	Configurable warning/disable system for overcurrent event.



PARAMETER (UNIT)	VALUE	NOTES
Over Temperature Protection	Configurable	Configurable warning/disable system for over temperature event.
Short Circuit Protection	✓	Hardware short circuit protection (Constant Current Mode).
Output HW Overcurrent Protection Mode	Constant Current Mode	—

Physical

PARAMETER (UNIT)	VALUE	NOTES
Weight	(g) 55 [1.94 oz]	Base weight only, not including cables.
Operating Temperature	(°C) -20 to 50 [-4 to 122°F]	Continuous operation above 50°C [122°F] may reduce lifetime of unit.
Dimensions	(mm) 17.23 x 96.4 x 50 [0.68 x 3.8 x 1.97 in]	H x W x D
IP Rating	x	Provided as an unprotected bare board. Consult 05 Integration for more information.
Input Connector	Molex Micro-Fit+ 2x2	—
Output Connector	Molex CLIK-Mate 10x2	—
CAN Connectors	2x JST GH 4 Pin	Connected in parallel internally for daisy-chaining.
Fan Connector	1x JST GH 3 Pin	JST BM03B-GHS-TBT(LF)(SN)

Channel Voltages

PARAMETER (UNIT)	VALUE	NOTES		
Output Voltage	(V)	Digitally selectable within the Hargrave Configurator. All voltages are selectable for both outputs.		
	• 3.3		• 11.1	• 21
	• 5.0		• 12	• 21.2
	• 5.4		• 12.9	• 22.7
	• 6.3		• 13.3	• 22.9
	• 7.2		• 15	• 23
	• 8		• 16	• 24
	• 8.2		• 17.9	• 24.9
	• 8.4		• 18.2	• 25.7
	• 10		• 19	• 26
	• 10.1		• 20	• 28
• 10.3	• 20.8			



This quick start guide is a helpful starting point for integrating the microFLUX 2MPi into a system, but is by no means exhaustive.

Please read the datasheet and online documentation before full vehicle testing.

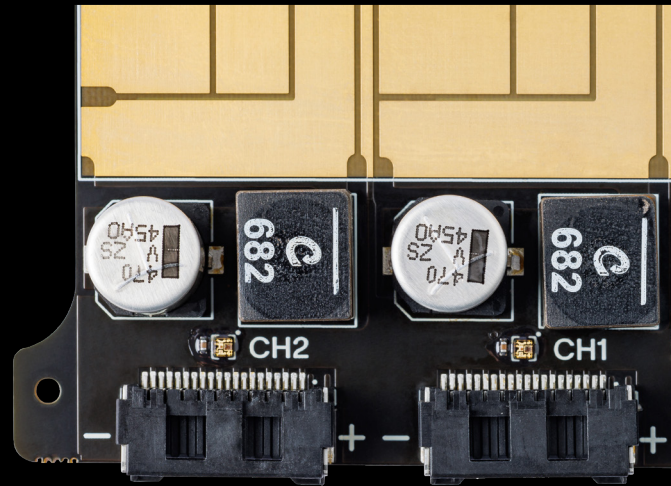

04 Quick Start

It is important to note that the microFLUX 2MPi can never output a voltage higher than the supplied bus voltage.

Communications

- Before use, configure the output voltage and power-on behavior of each output channel using the quick start guide within the **Hargrave Configurator Tool**.
- Enable the CAN terminator on the unit furthest away from flight controller if no other CAN devices are terminating the bus.

Mounting

Ensure the mounting solution provides protection to the heat-sink area to prevent water or debris shorting the exposed copper. A thermal pad or similar must be used between the heat-sink area and any conductive surfaces to prevent shorts.

- Ensure all connected cables are externally strain-relieved for long-term reliability.
- Ensure the microFLUX 2MPi is mounted in a location with appropriate environmental protection.
- Ensure the large exposed copper area is protected from accidental contact using a non-conductive material.

Protection Systems



Activation of protection mechanisms may cause unexpected system responses, including outputs disabling. It is important to understand these behaviors and configure them to its integrated system. More information is available in **07 Protection Systems**.

Configurator

Try our guided Quick Start and configure the microFLUX 2MPi with the Hargrave Configurator Tool at:

configurator.hargravetechnologies.com

All settings are accessible over CAN.

Connectors & Cables

Below are the manufacturer part numbers for mating connectors and pre-terminated wires needed to connect to the input and outputs of the microFLUX 2MPi. Weight can be minimized by fine tuning the wire size based on system current draw. For details, consult **05 Integration**.

- Bus Input Mating Connector Housing - Molex 2064610400
- Bus Input 16 AWG Pre-terminated Wire - Molex 0367693064 (x4)
- Output Channel Mating Connector Housing - Molex 5031492000
- Output Channel 24 AWG Pre-terminated Wire - Molex 215711124 (x10 Black) and Molex 215711214 (x10 Red)
- Fan control connector - JST BM03B-GHS-TBT (LF)(SN)

Thermal Management

A thermal solution must be implemented to prevent the device from over-heating. A flat thermally conductive area is present on the connector side of the unit for attaching a heatsink to cool the device. A 12 V header is provided allowing for connection of a DC fan up to 200 mA.

For information on the cooling required see **06 Cooling & Performance**.



05 Integration

Wiring

A range of wire gauges can be used to connect to the microFLUX 2MPi. Wire size and its matching crimp should be chosen to match the expected current at the bus input and channel outputs. To calculate your input current, use the following:

1. Channel Output Power = Output Voltage × Output Current

2. Channel Input Power = Channel Output Power + Loss

3. Total Input Power = \sum Channel Input Power

4. Max Input Current = $\frac{\text{Total Input Power}}{\text{Lowest Battery Voltage}}$

Channel loss can be found using the graphs in **06 Cooling & Performance**.

Bus Input

Connector Used: Molex Micro-Fit+ 2x2 (2125280401)

Mating Connector Housing: Molex 2064610400 OR 2064610410

Ensure all 4 contacts are equally loaded.

Choose wire gauge and crimp based on calculated input current. All crimps listed below are compatible with the mating connector housing.

CRIMP MPN	WIRE GAUGE	DEVICE INPUT CURRENT LIMIT (A)
2064600012	30	7.6
2064600012	28	9
2064600012	26	11
2064600022	24	12
2064600022	22	15
2064600022	20	17
2064600032	18	19
2064600042	16	22

Pre-terminated wires are available for fast integration such as 0367693064 (16 AWG) or 0367693071 (24 AWG).

Output Channels

Connector Used: Molex 1.5mm CLIK-Mate 10x2 (2132282011)

Mating Connector Housing: Molex 5031492000

Ensure all 20 contacts are equally loaded for full current delivery. Each contact pair delivers 1/10 of the rated current, allowing channels to power multiple loads appropriately.

Choose wire gauge and crimp based on channel output current limit. All crimps listed below are compatible with the mating connector housing.

CRIMP MPN	WIRE GAUGE	CHANNEL OUTPUT CURRENT LIMIT (A)
2130293000	28	10
2130293000 OR 2130283000	26	15
2130283000	24	20

Pre-terminated wires are available for fast bring-up such as 2157111124 (24 AWG, Black) and 2157112124 (24 AWG, Red).



Capacitance

Excessive capacitance on the output of the power supply can result in non-ideal regulator start-up or failure to start entirely due to inrush current. To guarantee controlled start-up, ensure connected devices don't present larger capacitance than shown below:

- $V_{out} \leq 12\text{ V} = 6.0\text{mF}$
- $V_{out} > 12\text{ V} = 2.0\text{mF}$

Inductive Loads

When using with inductive loads, ensure that any voltage spike observed on the microFLUX output when switching does not exceed the rated voltage.

CAN Voltage Supply

To power the CAN isolator, a four-pin CAN cable with a 5 V - 12 V power pin must be used.

Parallel / Series Channel Connection

Never connect multiple channels in series to increase output voltages. Channel outputs are not isolated and share a common ground.

It is not recommended to connect channels in parallel. Connecting in parallel cannot guarantee increased current rating.

Any Questions?

We're here to help. Reach out directly to our engineering team at:

contact@hargravetechnologies.com

Mounting

The microFLUX 2MPi offers 6 mounting holes to secure the unit to your application. These are best suited to M2 bolts. Ensure you use a tightening torque appropriate to the fastener and the mounting material you are using. For detailed mounting information refer to the example integration CAD on [page 10](#).

microFLUX 2MPi is primarily designed for use in aerial vehicles; vibration isolation of the unit, particularly in land-based applications, will increase its longevity. To reduce the chance of connection joints failing, ensure there is appropriate mechanical strain relief on all cables attached to the unit.

An example integration is available on [page 10](#). A mounting sled for microFLUX 2MPi is available to purchase separately.

Ingress Protection

microFLUX 2MPi is provided as an unprotected bare board. A selective conformal coat is applied but does not provide full coverage. The integrator must ensure the microFLUX 2MPi is adequately protected from debris, water and physical impact.

In particular, care should be taken around the heat-sinking area and the solder pads. Exposure to heavy dust, rain, or submersion can result in unit failure. Ensure that the microFLUX 2MPi is mounted in a location with appropriate environmental protection to reflect the UAV's operating conditions.

Thermal Management

Thermal constraints must be considered when integrating the microFLUX 2MPi. When designing the thermal solution it is recommended to bond to the exposed heat-sink area on the connector side of the unit, through an electrically non-conductive thermal interface material (TIM). The graphs in [06 Cooling & Performance](#) can be used to estimate the thermal loss that needs to be dissipated depending on your loading condition.

A heatsink is available to purchase separately for microFLUX 2MPi. Using the heatsink airflow of 8 m/s is required to allow continuous full output power with a 50°C temperature rise at the hottest point. Without any heatsink, 20 m/s is required to allow continuous full output power.

Various configurable temperature protection systems are available to monitor device and channel temperatures, allowing for early warning and over-temperature responses. Caution should be taken if operating without any heat-sink as a significant temperature difference can occur between the temperature sensor and the hot spots.

The heat generating zones on the microFLUX 2MPi are highlighted on the drawing below.

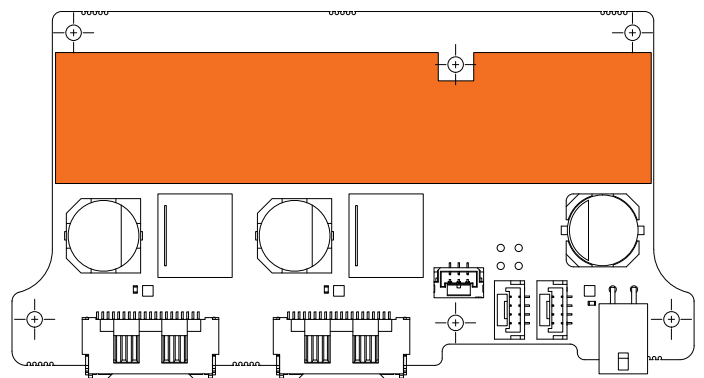



Example Integration

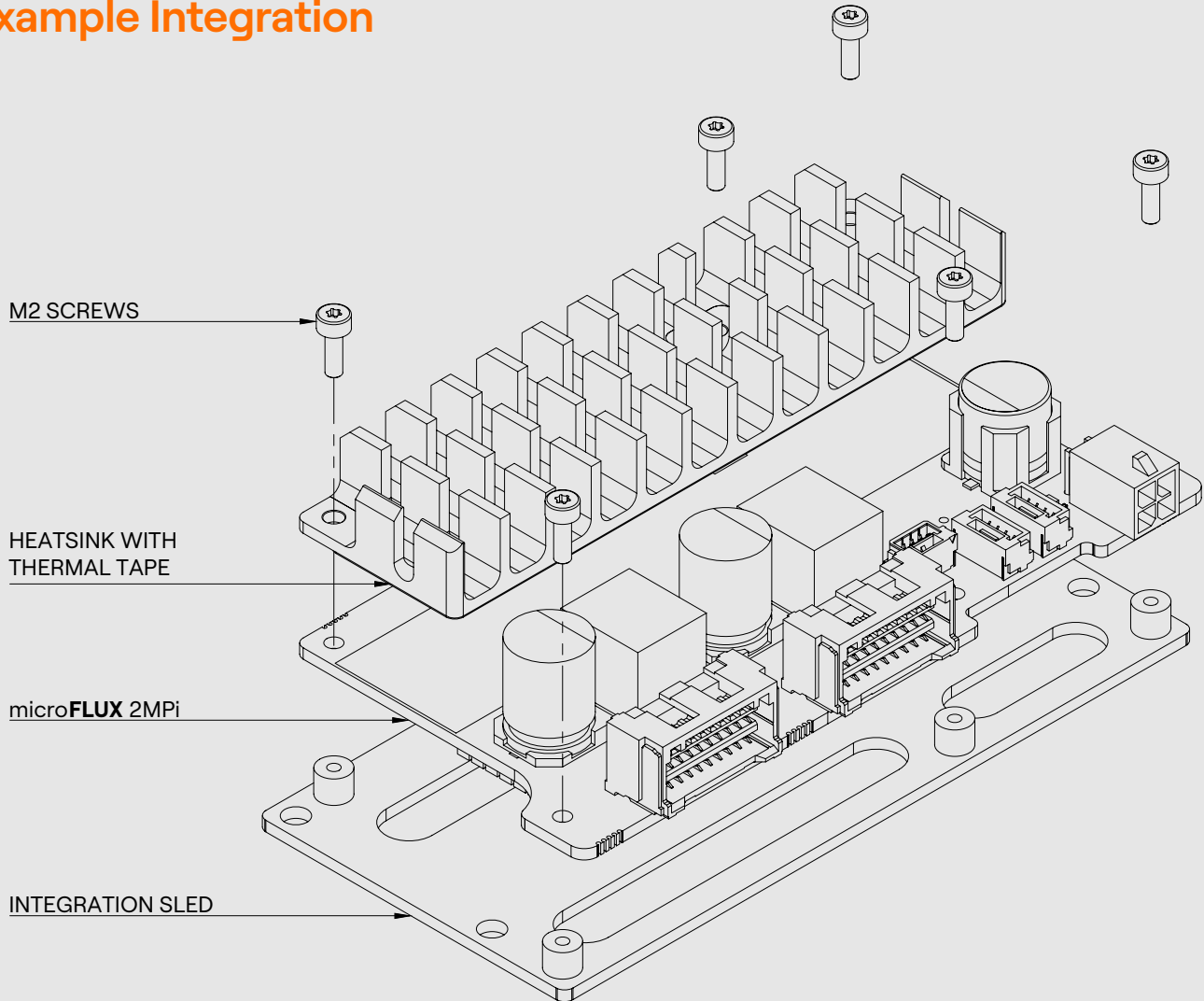

Looking for the CAD?

Click below to find the new
microFLUX 2MPi integration CAD:
hrgve.tech/uF-2MPi_Integration

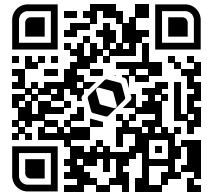

The secret is in the source

All Hargrave Technologies products are engineered, manufactured and tested in Australia from first class components. Australia is classed as a domestic source under Title III of the United States Defense Production Act.



Because of this, we can produce units that are compliant with the United States National Defense Authorization Act 2023 – generally required for suppliers to United States Government agencies. All variations of the microFLUX 2MPi are NDAA compliant, with all legislated components sourced outside of the NDAA “countries of concern”, including the People’s Republic of China. It is also EO13981-compliant.



Key Dimensions

The below drawings can be used as a reference for designing your own thermal solution for the microFLUX 2MPi. All relevant dimensions including those of the exposed copper area and hole positions are shown.

We recommend that your thermal solution/ heatsink covers this area of copper to ensure adequate thermal transfer and to protect it from contact, as it is live.

The next section, **06 Cooling & Performance** contains the relevant data for ensuring your thermal solution dissipates the required energy for your given use case.

Hole positions

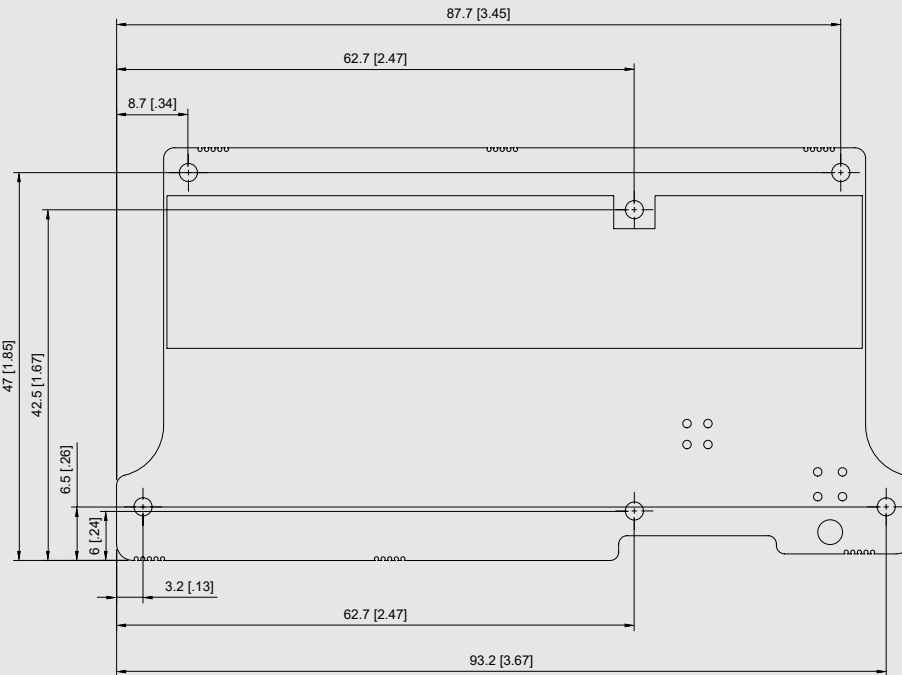

Copper Area

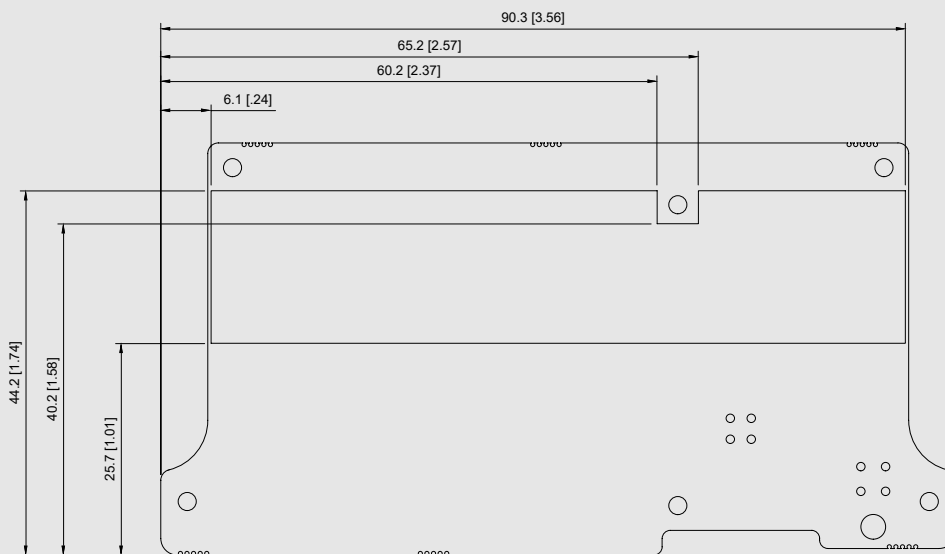

All dimensions in mm [inches].

Drawings not to scale.

Components hidden for clarity.



06 Cooling & Performance

Typical performance characteristics measured at 25°C ambient temperature unless otherwise stated.

Output Current Rating

- 20 A / Channel

Derating may be required to prevent excess temperature depending on environmental conditions, thermal solution, unit configuration and input voltage. Parallel airflow over the unit using the available integration heatsink of 8 m/s (20 m/s without any heatsink) is sufficient to allow any configuration and any input voltage with a temperature rise of 50°C or less. Use the below graph to find an estimate of the airflow needed for your total current draw (sum of the current draw from both outputs).

Total Current Draw vs Required Airflow

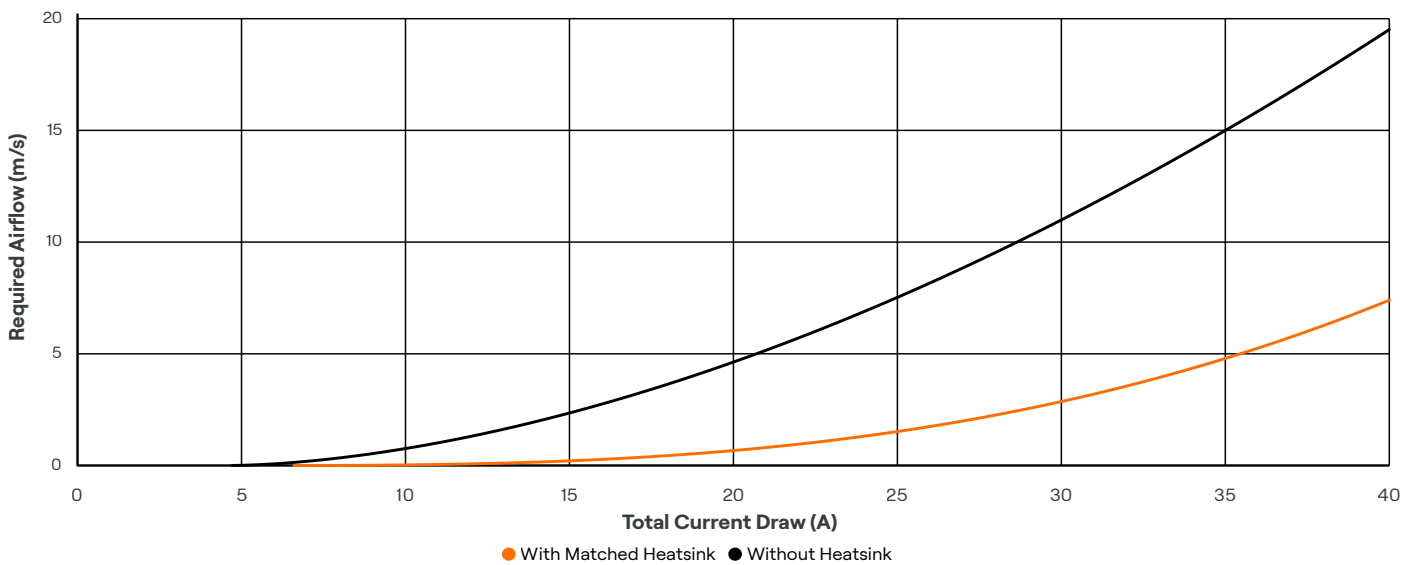

Measured at worst case operating points and airflow parallel to the device, allowing for a 50°C temperature rise

For more detailed optimization of the microFLUX 2MPi into your aircraft, use the Channels Loss graphs available on Page 13 and 14 to find the loss for each output channel at its output voltage and current draw. Then use the sum of the losses for each of the channels and the graph below to find the perpendicular airflow needed to cool your unit.

Total Power Dissipation vs Required Airflow

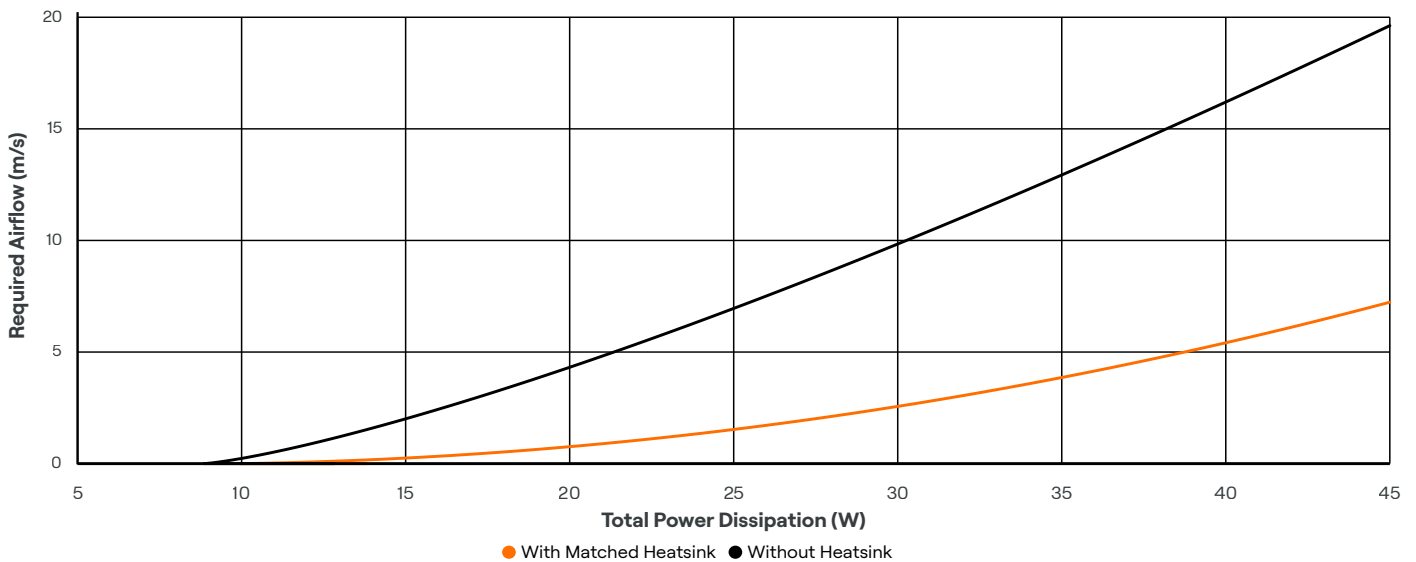

Measured with airflow parallel to the device, allowing for a 50°C temperature rise.

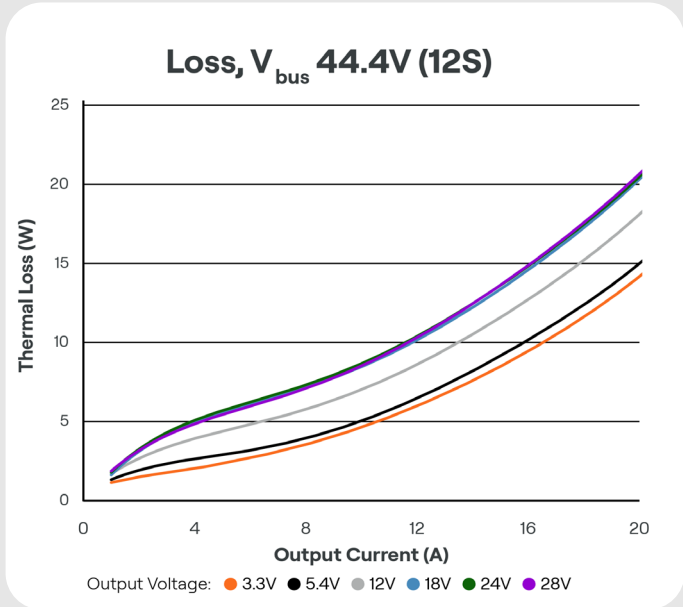
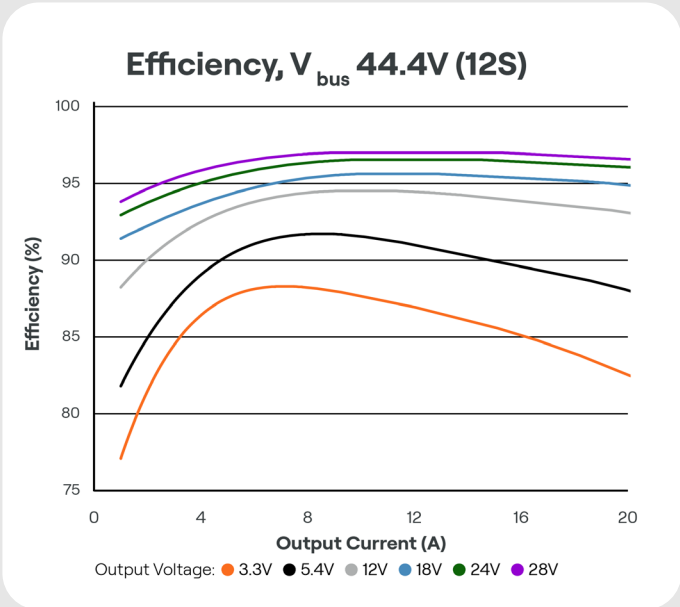
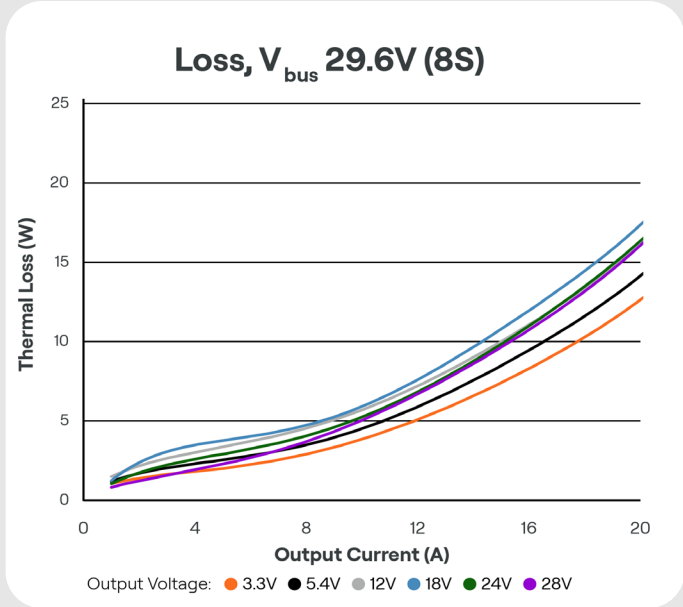
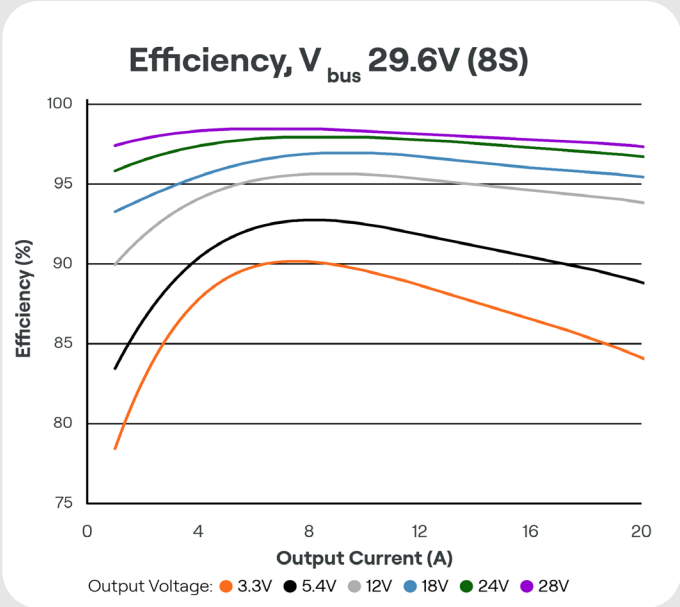
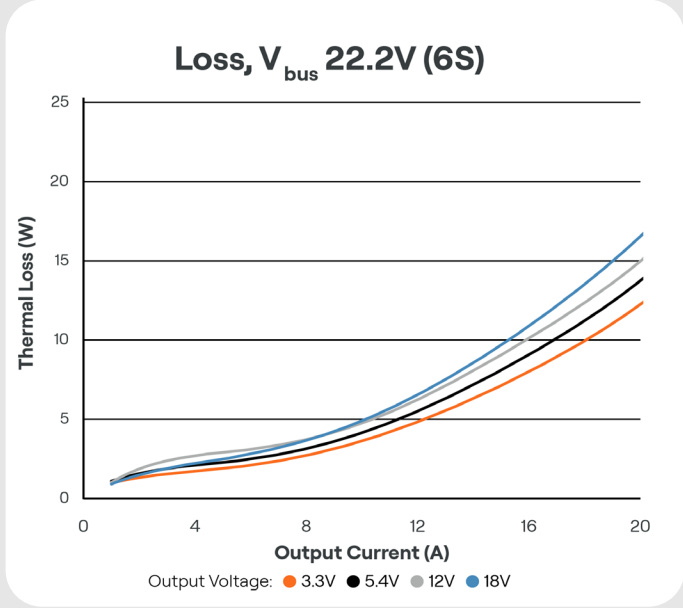
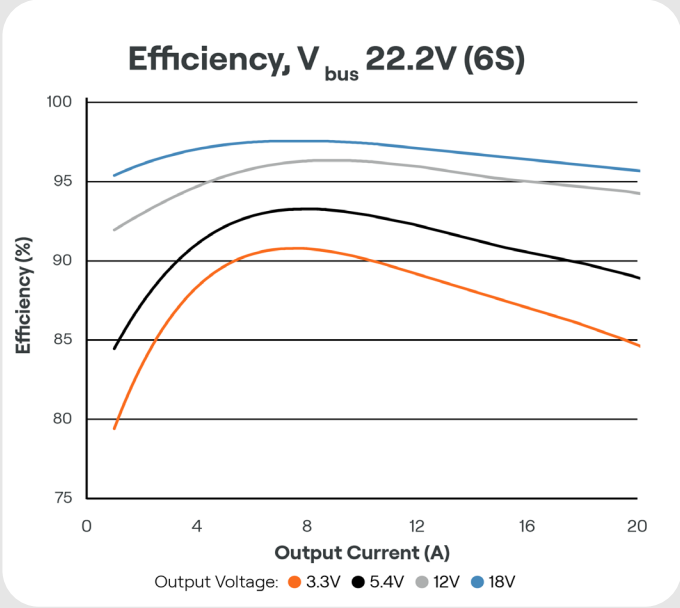



Efficiency, V_{bus} 51.8V (14S)

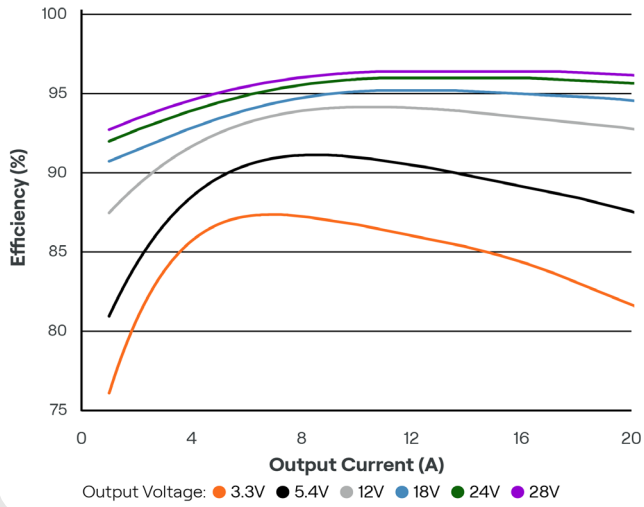

Loss, V_{bus} 51.8V (14S)

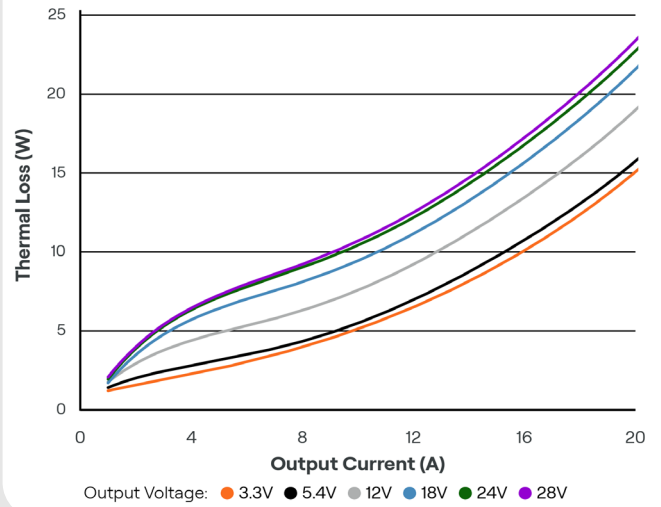

Speak to us

For any questions about performance in specific applications, reach out to our engineering team at:

contact@hargravetechnologies.com



07 Protection Systems

TYPE	PROTECTION	RESPONSE	USE	HARDWARE (HW) FALLBACK
Per Channel	Undervoltage Response	Adjustable warning & error limits. If the voltage drops below the error limit the channel can be shut off (Optional).	Detects a decrease in the output voltage due to an excessive load current, insufficient input voltage or internal hardware failure.	No.
Per Channel	Overvoltage Response	Adjustable warning & error limits. If the voltage rises above the error limit the channel can be shut off (Optional).	Detects an increase in the output voltage due to back-feeding, voltage spikes from switching inductive loads or internal hardware failure.	No.
Per Channel	Over Temperature Response	Adjustable warning & error limits. If temperature exceeds the error limit the channel can be shut off (Optional).	Prevents the unit from reaching unsafe temperatures as defined by the application.	No.
Per Channel	Undercurrent Response	Adjustable warning limit. Exceeding it sends a warning message.	Detects lower than expected load current draw, indicative of a downstream problem.	No.
Per Channel	Overcurrent Response	Adjustable warning & error limits. If current exceeds the error limit the channel can be shut off (Optional).	Prevents downstream devices from drawing power exceeding their allocated power budget and flags downstream problems causing excessive current draw.	Yes, channel will enter a constant current mode at the maximum current limit, resulting in output voltage reducing.
System	Bus Undervoltage Response	When the bus voltage falls below the error limit all channels can be turned off, or only non-priority channels are turned off (Configurable).	Provides an early-warning of low battery or supply sag and prevents over-discharge of batteries.	No.
System	Bus Overvoltage Response	Adjustable warning & error limits. When the bus voltage rises above the error limit all channels can be turned off, or only non-priority channels are turned off (Configurable).	Detects voltage spikes at the bus and minimizes effect on downstream components or damage to the unit.	No.
System	Bus Overcurrent Response	Adjustable warning & error limits. When the bus current exceeds the error limit all channels can be turned off, or only non-priority channels are turned off (Configurable).	Detects situations where the current limit of the unit input exceed its ratings and prevents damage to the device.	No.
System	Bus Over Temperature Response	Adjustable warning & error limits. When the bus temperature exceeds the error limit all channels can be turned off, or only non-priority channels are turned off (Configurable).	Prevents the unit from reaching unsafe temperatures as defined by the application.	No.



08 Ordering Options

FLUX

SKU	Channels	NDAA Compliant
106387	2 x 20 A Output Channels	✓

Accessories

SKU	Accessory	CAD
106312	Mounting Sled (incl. M2 mounting screws - PCB to Sled)	hrgve.tech/sled_L_CAD
106313	Heatsink (incl. Adhesive thermal tape)	hrgve.tech/heatsink_L_CAD



09 Pinouts

Control Signal - CAN

JST BM04B-GHS-TBT (LF)(SN)

Mates to:
JST GHR-04V-S

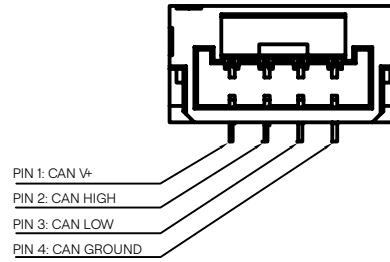
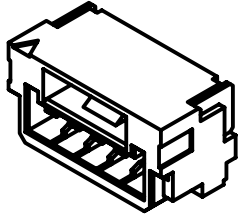

Power - Output

Molex 2132282011

Mates to:
Molex 5031492000

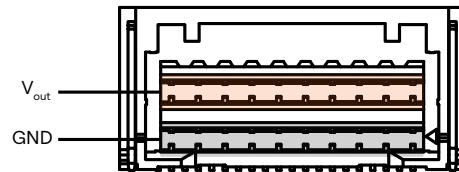
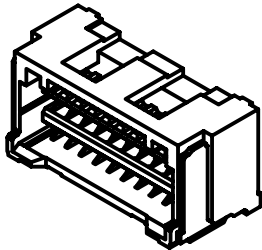

Power - Input

Molex 2125280401

Mates to:
Molex 2064610400 OR 2064610410

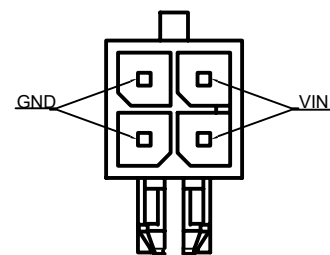
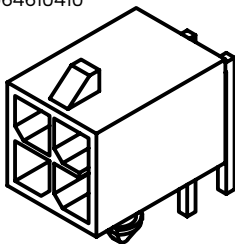

Fan - Control

JST BM03B-GHS-TBT(LF)(SN)

Mates to:
JST GHR-03V-S

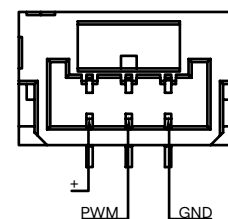
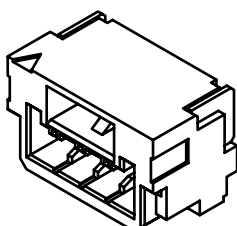



10 Powered by GateKEEPER

GateKEEPER is the unified technology core that underpins the next generation of Hargrave Technologies' power electronics. It encompasses everything we've learnt through over a million flight hours with our development partners and extends it with CAN, advanced data-logging and class leading protection systems.

Using GateKEEPER, we can share a common hardware and firmware foundation across our range of power electronics, so they can all benefit from the diversity and longevity of applications demanded by modern UAS. Shared architecture allows us to collect a wider range of flight data, allowing us to minimize long term reliability risks across a broad range of products.

We can use GateKEEPER to rapidly develop bespoke electronics specific to your application, with the reliability of an extensively flight-validated core shared with our COTS products.

Response Ready.

Contact us.

Sales

To find out more about how to take off with microFLUX 2MPi, get in touch with our sales engineers at:

sales@hargravetechnologies.com

Documentation

For a detailed technical overview and operations manual, visit:

docs.hargravetechnologies.com

Technical

For any technical questions, please reach out to a technical contact at Hargrave or email us at:

contact@hargravetechnologies.com



11 Revisions

Revision	Date	Description
1.0	26/06/2026	Datasheet Release
1.1	29/06/2026	Update to current draw graph unit of measure.

12 Disclaimer

This power supply datasheet is provided for informational purposes only. This power supply is designed and intended solely for use in uncrewed aerial vehicles (UAVs) and drones. It is not intended for any other applications in which a malfunction or failure may cause loss of life, injury or property damage, including but not limited to crewed aviation.

Hargrave Technologies Pty Ltd (ABN 45 670 453 120) and its Related Bodies Corporate are collectively referred to as "Hargrave". Hardware, software and related technologies described in this document are collectively referred to as "Product".

By using Product, you agree that:

- Product is specifically designed only for use in UAVs. Any other use is not supported or recommended without consultation with Hargrave.
- Hargrave Technologies reserve the right to change the data provided in this datasheet at any time without prior notice. It is the responsibility of the user to ensure that they have the most up-to-date information.
- The information contained in this datasheet is proprietary and confidential. Reproduction, distribution, or any other use of this information without the explicit permission of Hargrave is strictly prohibited.
- Product may be controlled under the Australian Defence Trade Controls Act. Unauthorized export or re-export of Product is prohibited without explicit permission from Hargrave. It is the responsibility of the user to comply with all applicable export control laws and regulations.
- Reverse engineering of Product, including but not limited to disassembly, decompilation, or any other attempt to derive the source code or underlying technology, is strictly prohibited.
- Hargrave shall not be liable for any damages, injuries, or losses arising from the use of Product in unspecified applications.
- Hargrave shall not be liable for any loss of income, profits, or property resulting from the use or inability to use Product, even if advised of the possibility of such damages.
- Hargrave shall not be liable for any damages, injuries, or losses resulting from the design, application, or integration of Product into customer projects or systems.
- Any modifications or alterations made to Product are strictly prohibited and may result in unsafe operation, voiding of warranty, and legal consequences.
- Product is only certified or compliant to standards and legislation explicitly mentioned in this document. Any other certifications or compliance not explicitly stated herein are not applicable.
- It is the responsibility of the user to seek guidance from Hargrave for any applications other than UAVs to determine suitability, compliance, and safety.
- By using Product, you acknowledge and agree to abide by the terms of this disclaimer. If you do not agree with these terms, you must not use Product for any purpose.

Please consult Hargrave for guidance on the use of Product in applications other than UAVs.